





Reversible pendulum with Cobra SMARTsense



The goal of this experiment is to investigate the principle behind the reversible pendulum.

Physics	Mechanics	Vibrations & waves	
Physics	Mechanics	Gravity / Gravitation	
 Difficulty level medium	 Group size 1	 Preparation time 45+ minutes	 Execution time 45+ minutes

Your local Partner

EL ESLEK

1, rue Montevideo, 2000 Le Bardo, Tunisia
 Tel. : +216 71 58 46 90 – Fax : +216 71 58 43 55
 contact@eleslek.com

PHYWE
excellence in science

General information

Application

PHYWE
excellence in science

Setup

A pendulum is a body suspended from a fixed support so that it swings freely back and forth under the influence of gravity. When a pendulum is displaced sideways from its resting, equilibrium position, it is subject to a restoring force due to gravity that will accelerate it back toward the equilibrium position. When released, the restoring force acting on the pendulum's mass causes it to oscillate about the equilibrium position, swinging it back and forth. The mathematics of pendulums are in general quite complicated. Simplifying assumptions can be made, which in the case of a simple pendulum allow the equations of motion to be solved analytically for small-angle oscillations.

Other information (1/2)

PHYWE
excellence in science

Prior knowledge



The prior knowledge required is found in the theory section.

Scientific principle



By means of a reversible pendulum, terrestrial gravitational acceleration g may be determined from the period of oscillation of a physical pendulum, knowing neither the mass nor the moment of inertia of the latter.

Other information (2/2)

PHYWE
excellence in science

Learning objective



The goal of this experiment is to investigate the principle behind the reversible pendulum.

Tasks



1. Measurement of the period for different axes of rotation.
2. Determination of terrestrial gravitational acceleration g .

Theory (1/7)

 PHYWE
excellence in science

The physical pendulum (Fig. 1) differs from the mathematical pendulum by the fact that the oscillating mass is not concentrated in a single point but is distributed over a region of space.

The potential energy of a pendulum V results from the potential energy of the center of gravity \vec{S} ($|\vec{AS}| = s$):

$$V = \sum_i m_i \vec{r}_i \cdot \vec{g} = M \cdot \vec{S} \cdot \vec{g} = -Mgs \cdot \cos \Theta \quad (1)$$

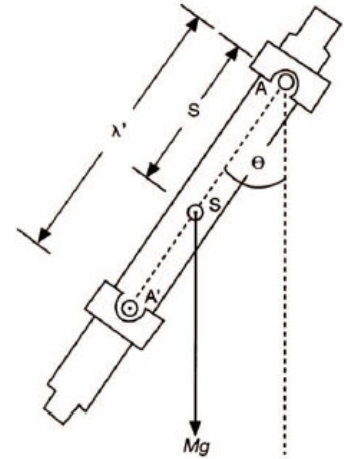

Fig. 1: Reversible pendulum.

Theory (2/7)

 PHYWE
excellence in science

m_i and \vec{r}_i are the mass and the position vector of the i -th particle related to the axis of rotation A ; M is the total mass of the pendulum and g the terrestrial gravitational acceleration. The kinetic energy T_{kin} of the physical pendulum is the sum of the kinetic energies of its particles:

$$T_{kin} = \sum_i \frac{1}{2} m_i \vec{v}_i^2 = \sum_i \frac{1}{2} m_i (\vec{\omega}_i \times \vec{r}_i)^2 = \sum_i \frac{1}{2} m_i \omega_i^2 r_i^2 \quad (2)$$

$\vec{\omega}_i$ is the angular velocity of the i -th particle ($\vec{\omega}_i \perp \vec{r}_i$), which, in case of a rigid body, is equal to $\dot{\Theta}$ for all the particles of the pendulum.

$$T_{kin} = \frac{\dot{\Theta}^2}{2} \sum_i m_i r_i^2 = \frac{\dot{\Theta}^2}{2} J = \frac{\dot{\Theta}^2}{2} (J_S + Ms^2) \quad (3)$$

The moment of inertia J related to the axis of rotation A was replaced in the last transformation by the moment of inertia of the pendulum J_S related to the parallel line running through the center of gravity S of the axis (Steiner's law).

Theory (3/7)

Applying conservation of energy to the system, one obtains:

$$E = T_{\text{kin}} + V = \frac{\dot{\Theta}^2}{2} (J_S + Ms^2) - Mgs \cdot \cos \Theta = \text{const}$$

This is a differential equation of the first order, which only has analytic solutions for small oscillations ($\cos \Theta \approx 1 - \Theta^2$; C is a constant):

$$\dot{\Theta}^2 + \frac{Mgs}{J_S + Ms^2} \Theta^2 = C \quad (4)$$

The general solution of (4) is:

$$\Theta(t) = \Theta_0 \sin(\omega t + \varphi) \quad (5)$$

where the oscillation amplitude is Φ_0 , the phase is φ and the oscillating frequency is given through:

Theory (4/7)

$$\omega = \frac{2\pi}{T} = \sqrt{\frac{Mgs}{J_S + Ms^2}} \quad (6)$$

Defining the reduced pendulum length λ_r as follows: $\lambda_r = \frac{J_S}{Ms} + s$ (7)

the period T of a plane physical pendulum is: $T = 2\pi \sqrt{\frac{\lambda_r}{g}}$ (8)

The period T is thus the same as that of a mathematical pendulum ($T_{\text{math}} = 2\pi \sqrt{l/g}$) with a length of $l = \lambda_r$. It is obvious, that on the one hand, the period of the physical pendulum depends on its mass, in opposition to the mathematical pendulum; on the other hand, the reduced length $l = \lambda_r$ of the pendulum is always larger than the distance s between the center of gravity and the axis of rotation, so that the oscillating speed of the pendulum will increase when the mass is concentrated nearer to the center of the gravity.

Theory (5/7)

Point A' , which is situated on the prolongation of \vec{AS} at a distance of $l = \lambda_r$ with respect to the axis of rotation (Fig. 1), is known as the center of oscillation. If the axis of rotation of the pendulum is displaced from A to A' (reversion), the period of the physical pendulum remains unaltered, because from equations (7) and (8) and the new distance of the axis of rotation from the center of gravity $|\vec{AS}| = \lambda_r - s$ it follows that:

$$T'_A = 2\pi \sqrt{\frac{J_S}{Mg(\lambda_r - s)} + \frac{\lambda_r - s}{g}}$$

$$= 2\pi \sqrt{\frac{J_S}{Mg} \frac{1}{\lambda_r - s} + \frac{J_S}{Mgs}} = 2\pi \sqrt{\frac{\lambda_r}{g}} = T_A$$

Theory (6/7)

A physical pendulum thus always has, for every axis of rotation A , a center of oscillation A' ; the period is the same if both points act as axis of rotation ($T_A = T'_A$). Furthermore, in this experiment, the periods are the same in case of symmetry (the bearing axes are equidistant of the center of gravity S); that is: $T_1 = T_2$ (cf. Fig. 2). Furthermore, it follows from Fig. 2 that on the one hand, near the center of gravity, the period tends towards infinite and on the other hand, that there exists an axis of rotation (for λ_{min}) for which the period is minimum.

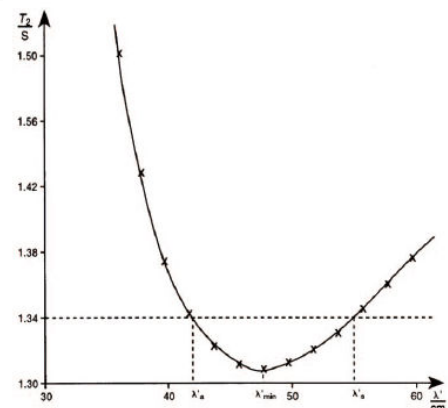

Fig. 2: Period T_2 as a function of the position of the axis of rotation of the physical pendulum.

Theory (7/7)

In Fig. 2, the modification of the moment of inertia and the shifting of the center of gravity due to the displacement of the bearing sleeves over the support rod was not taken into account (however, the basic pattern remains unchanged). This error becomes evident during the control measurement of period T_1 around axis of rotation 1, the value of which, $T_1(\lambda_a)$, is obviously different from the value obtained for the symmetrical case $T_1(\lambda'_s)$.

Equipment

Position	Material	Item No.	Quantity
1	Bearing bosshead	02805-00	2
2	Support rod, stainless steel, 750 mm	02033-00	1
3	Bolt with knife-edge	02049-00	2
4	Power supply 5 V DC/2.4 A with 4 mm plugs	11077-99	1
5	Cobra SMARTsense - Photogate, 0 ... ∞ s (Bluetooth + USB)	12945-00	1
6	Right angle clamp expert	02054-00	3
7	Bench clamp expert	02011-00	2
8	Tripod base PHYWE	02002-55	1
9	Support rod, stainless steel, l = 250 mm, d = 10 mm	02031-00	3
10	Measuring tape, l = 2 m	09936-00	1

PHYWE
excellence in science

Setup and Procedure

Setup and Procedure (1/4)

PHYWE
excellence in science

The Cobra SMARTsense Photogate and measureAPP are required to perform the experiment. The app can be downloaded for free from the App Store - QR codes see below. Check whether Bluetooth is activated on your device (tablet, smartphone).



measureAPP for Android operating systems



measureAPP for iOS operating systems



measureAPP for Tablets / PCs with Windows 10

Setup and Procedure (2/4)

PHYWE
excellence in science



Fig. 3: Experimental setup

The experimental set-up is illustrated in Fig. 3. The knife-edges must be fixed at the same height so as to make sure the mass of the pendulum will be distributed evenly over both bearing points.

The experimental table may not move with the pendulum, else a too small effective value for terrestrial gravitational acceleration g will be measured. This may require fixing the table to the floor.

Setup and Procedure (3/4)

PHYWE
excellence in science

The bearing sleeves (referred to in the following as 1 and 2) are each screwed at about 7 cm to 10 cm from the ends of the corresponding support rods. The position of bearing sleeve 1 will no longer be changed during the course of the experiment. The period T of the pendulum is determined for small oscillating amplitudes with the fork light barrier.

The light barrier is operated in the "period measurement" mode (switch shifted to the right side) and situated at the point of maximum amplitude of the pendulum. The time elapsed between two consecutive phases is measured, when the pendulum just leaves the infrared beam. This lapse of time is the period T at the point of maximum amplitude, as long as the pendulum keeps covering the beam while it reverses its trajectory.

Setup and Procedure (4/4)

PHYWE
excellence in science

At first, period T_1 is determined, with bearing sleeve 1 as rotation axis. Then period T_2 , with bearing sleeve 2 as a rotation axis, is determined as a function of distance λ' between the bearing points of both bearing sleeves (bearing sleeve 1 having a fixed position). For this, a measuring range $\lambda' = 34 \dots 60$ cm with a measurement interval $\Delta\lambda' = 2$ cm is recommended. Distances λ'_s and λ'_a , for which the periods of oscillation T_2 are equal to T_1 , are determined graphically.

For control, the duration of oscillation $T_1(\lambda'_a)$ is determined in the asymmetric case, that is with bearing sleeve 1 as axis of rotation.

To determine terrestrial gravitational acceleration g , the corresponding oscillating periods T_1 and T_2 are determined in the interval between $(T_1(\lambda'_a) - 3 \text{ cm})$ and $(T_1(\lambda'_a) + 3 \text{ cm})$ (bearing sleeve 1 remaining fixed) and are plotted against λ' .

PHYWE
excellence in science

Evaluation

Results (1/2)

PHYWE
excellence in science

Bearing sleeve 1: distance between the axis and the tip of the pendulum: 9.5 cm

$$T_1 = 1.340 \text{ s } (= T_1(\lambda'_s))$$

Control measurement for the asymmetric case:

$$T_1(\lambda'_a) = 1.324 \text{ s, for } \lambda'_a = 42.3 \text{ cm (Fig. 3)}$$

If one measures simultaneously the periods T_1 and T_2 for oscillations around both axes, for different distances λ' of the axes of rotation, as shown in Fig. 4, the intersection of both graphs for the asymmetric case allows to determine both the reduced length of the pendulum $\lambda_r = \lambda'_a$ and the corresponding period T .

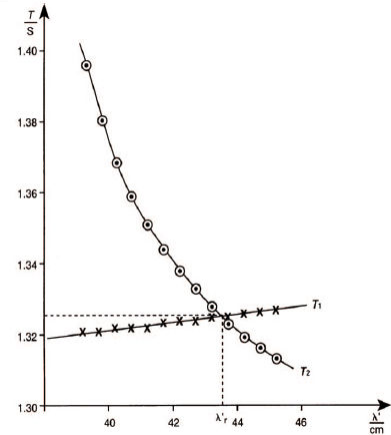

Fig. 4: Determination of the reduced pendulum length.

Results (2/2)

PHYWE
excellence in science

If equation (8) is converted according to the terrestrial gravitational acceleration g , one obtains:

$$g = \left(\frac{2\pi}{T}\right)^2 \lambda_r \quad (9)$$

Thus, terrestrial gravitational acceleration g can be determined from the coordinates of the point of intersection in Fig. 4.

The values $T = T_1 = T_2 = (1.325 \pm 0.001) \text{ s}$ and $\lambda_r = (43.6 \pm 0.1) \text{ cm}$

yield the following result:

$$g = (9.80 \pm 0.04) \text{ m/s}^2 \text{ (value given in literature: } g = 9.81 \text{ m/s}^2)$$